

BUFFER TANK
NBT-30SW

Wall-mounted

Capacity:
30 l



Installation Manual

Before operating this product, please read the instructions carefully and keep this manual for future use.





Before installing and operating the tank, please read this "Installation and Operating Instructions" and the Warranty Terms and Conditions.

Contents

1. Construction and purpose.	3
2. Security and conditions for safe use.	4
3. Operation and maintenance.	4
3.1. Installing an electric heater.	5
4. Warranty terms.	7



The manufacturer reserves the right to make any design changes as part of product modernization without having to include them in this manual.

1. Construction and purpose.

NBT-30SW buffer tanks are designed primarily for use with heat pumps. Their purpose is to collect, store, and transfer excess hot water for heating or other fluids approved for contact with carbon steel. NBT-30SW serve as a hot water storage tank for the heat pump's defrost function. They also protect the central heating system by absorbing the difference between the heat pump's thermal output and the output transferred to the heating system.

The buffer tanks are made of black sheet steel. Thermal insulation is provided by a layer of polyurethane foam. The thermal insulation is provided by a casing made of thin sheet steel with a powder-coated finish, and the lower and upper covers are made of ABS plastic.

Buffers are pressure devices designed to work in a vertical position with a maximum water pressure of 0.3 MPa (3 bar).

Fig.1 Construction of the NBT-30SW.

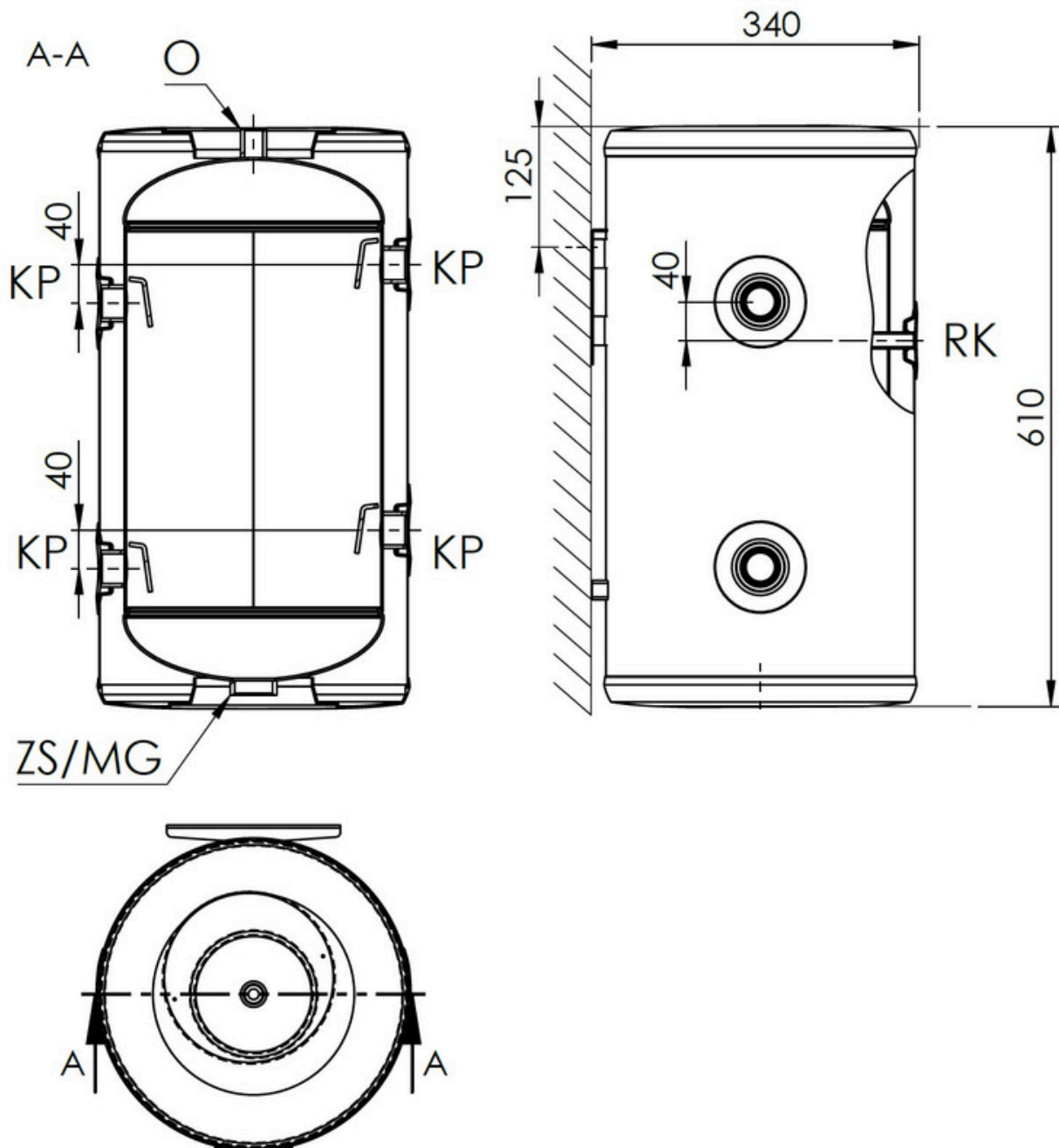

Table 1. Technical data of the NBT-30SW tank.

Parameter	Unit	NBT-30SW
Capacity	l	27
Connection stub	KP	G 1"
Temperature sensor	CT	3/8"
Electric heater	MG	G 1 ¼"
Drain	ZS	G 1 ¼"
Venting	O	G ½"
Tank type		steel – inside raw
Thermal insulation		polyurethane foam
Thermal insulation thickness	mm	25
Standby losses	W	31
External cover	sheet metal shell covered with powder paint	
Tank operating parameters	Maximum operating pressure: pr = 0,3 MPa	
	Maximum operating temperature: tr = 95°C	
Weight	kg	18

*in accordance with the applicable EU Commission Regulation No. 812/2013 and 814/2013

2. Security and conditions for safe use.

Tanks, especially those operating in closed systems, must only be operated with a functional safety valve with a maximum opening pressure of 0.3 MPa, preferably installed on the cold water inlet. This valve protects the device against excessive pressure buildup in the heating circuit. Even during normal operation, water may temporarily escape from the safety valve, indicating that the valve is functioning properly. In such cases, the discharge opening must not be blocked in any way.



1. Safety valve must be installed on the cold water inlet to the tank. It should be installed so that the arrowhead on the valve body aligns with the direction of water flow.
2. No shut-off valves should be installed between the safety valve and the tank.
3. Operating the tank without a safety valve or with a faulty safety valve is prohibited as it may cause a malfunction and pose a threat to human life and health.
4. For a safety valve that has, among other functions, the function of reducing the water pressure in the tank by flowing it into the supply system, the water supply system at a distance of at least 5 m from the valve should be resistant to a temperature of +90°C.

3. Operation and maintenance.

1. Periodically, at least once a month and before each start-up after being taken out of service, check the correct operation of the safety valve.
2. Repairs to water installations should only be carried out by professionals with appropriate qualifications.

3.1. Installing an electric heater.

NBT-30SW tanks allow for the installation of an electric heater designed for use in tanks without an internal ceramic coating. The heater should be screwed into the 1 1/2" socket located in the lower bottom of the buffer tank, after removing the plastic cover. To do this, unscrew the two metal screws (Fig. 2 - items 1 and 2), and then remove the round plastic cap covering the heater socket. After removing the plug covering the heater socket, re-screw the plastic collar (Fig. 2 - item 3) to the bottom. After completing the above steps, you can begin screwing in the electric heater. Installation should be performed in accordance with the electric heater's installation and operating instructions.

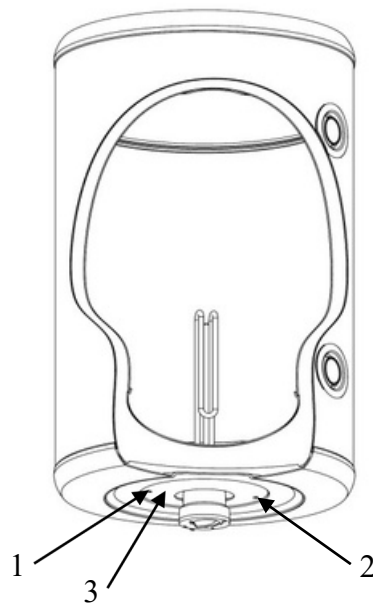

Fig. 2. Installing the electric heater.



Do not plug the heater's connecting cable into an electrical outlet without first ensuring that the tank is filled with water.



The maximum immersion length of the heating element that can be installed in the tank heater coupling is:

- for NBT-30SW - 300 mm.



Due to the method of installation of the electric heater in the tank, it is necessary to ensure forced waterflow through the buffer by installing a circulation pump in order to reduce the risk of damage to the heating element.



To ensure proper flow in the central heating system, remember to also turn on the additional central heating circulation pump for the buffer tanks when switching on the electric heater.



Do not insert the heater's connecting cable plug into an electrical outlet without making sure that the tank is filled with water.

4. Warranty terms

1. The warranty for the tank (i.e., the enameled steel body of the exchanger) is 60 months.
2. The warranty for the remaining parts of the tank is 24 months.
3. The warranty period runs from the date of sale of the product to the user, as specified in the warranty card and confirmed by the purchase document (invoice) issued by the seller.
4. The guarantor guarantees the efficient operation of the exchanger provided that it is installed and used in accordance with this instruction manual.
5. During the warranty period, the user is entitled to free repairs of any damage to the heat exchanger caused by the manufacturer. Such damage will be repaired within 14 days of the report date.
6. The user loses the right to warranty repairs in the event of:
 - improper use of the device,
 - repairs and modifications to the device performed by unauthorized persons,
 - improper installation and operation of the device not in accordance with this manual,
 - operation of the exchanger without a safety valve or with a faulty safety valve,
 - negligence of maintenance, i.e., failure to replace the magnesium anode every 18 months (no proof of purchase: receipt, invoice, etc.),
 - using an electric heater with uninsulated heating elements,
 - dismantling the thermal insulation permanently attached to the pressure tank.
7. The guarantor may refuse to perform repairs if:
 - installation access to the device is not provided; to replace the heater it is necessary to dismantle other devices, partition walls, etc.,
 - the tank is permanently connected to the water supply system using non-detachable connections.
8. Each service request is preceded by an initial assessment to determine whether the fault described by the customer exists and whether the user has not been at fault due to improper use of the device.
9. In the event of a service call for an event not covered by the warranty, i.e. AFTER THE WARRANTY PERIOD EXPIRES, the costs of the service visit and the ordered repair are borne by the customer.
10. In the event of any irregularities in the operation of the exchanger, notify the manufacturer's service by phone at +37037373248, or by email at service@nordis-ac.com or at the point of purchase. DO NOT DISASSEMBLE THE DEVICE.
11. The method of repairing the device is determined by the manufacturer.
12. The warranty covers heat exchangers purchased and installed exclusively in the territory of the Republic of Lithuania.
13. In matters not regulated by the above terms, the provisions of the Civil Code apply.



More information about
NØRDIS heating and
cooling solutions

www.nordis-ac.com