

BUFFER TANK

NBT-SF

Floor standing



Capacity:

100 l
150 l
220 l
250 l
300 l
400 l
500 l

Installation Manual

Before operating this product, please read the instructions carefully and keep this manual for future use.





Before installing and operating the tank, please read this "Installation and Operating Instructions" and the Warranty Terms and Conditions.

Contents

1. Construction and purpose	3
2. Security and conditions for safe use	7
3. Operation and service	8
a. Installing a heater with an electric heater	8
4. Warranty terms	9



The manufacturer reserves the right to make any design changes as part of product modernization without having to include them in this manual.

1. Construction and purpose

NBT-SF buffer tanks are designed to collect, store, and transfer excess hot water or other fluids approved for contact with steel, obtained from various heat sources: central heating boilers, solar collectors, heat pumps, etc. Buffer tanks protect central heating systems by absorbing the difference between the boiler's thermal output and the output transferred to the heating system. The maximum operating pressure of the tank is 0.3 MPa.

Buffer tanks are made of black steel sheet. Thermal insulation is provided by a layer of polystyrene foam or a rubber mat permanently attached to the tank walls. The thermal insulation is protected by a jacket made of artificial leather.



NOTE! In the case of thermal insulation permanently attached to the pressure tank, its removal will result in the loss of the product warranty.

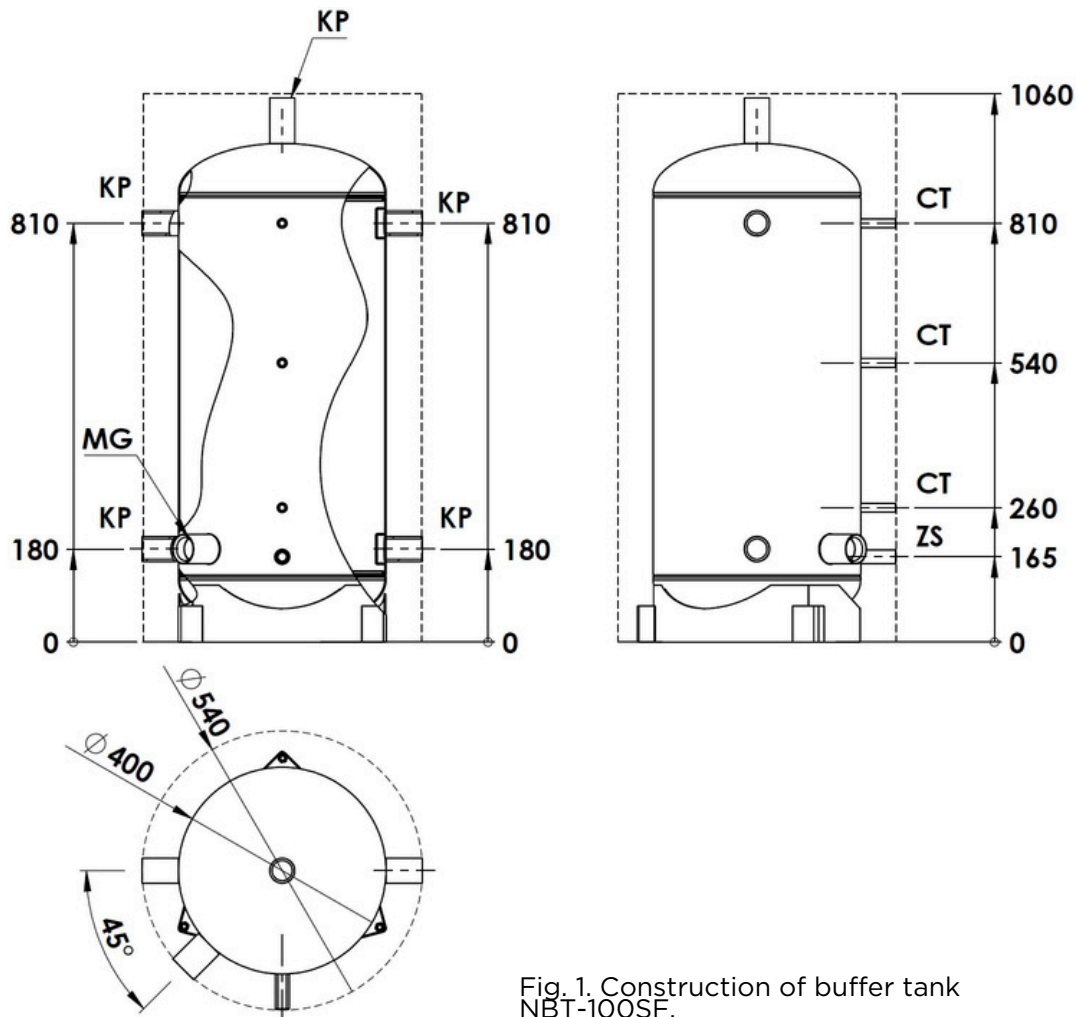

Fig. 1. Construction of buffer tank NBT-100SF.

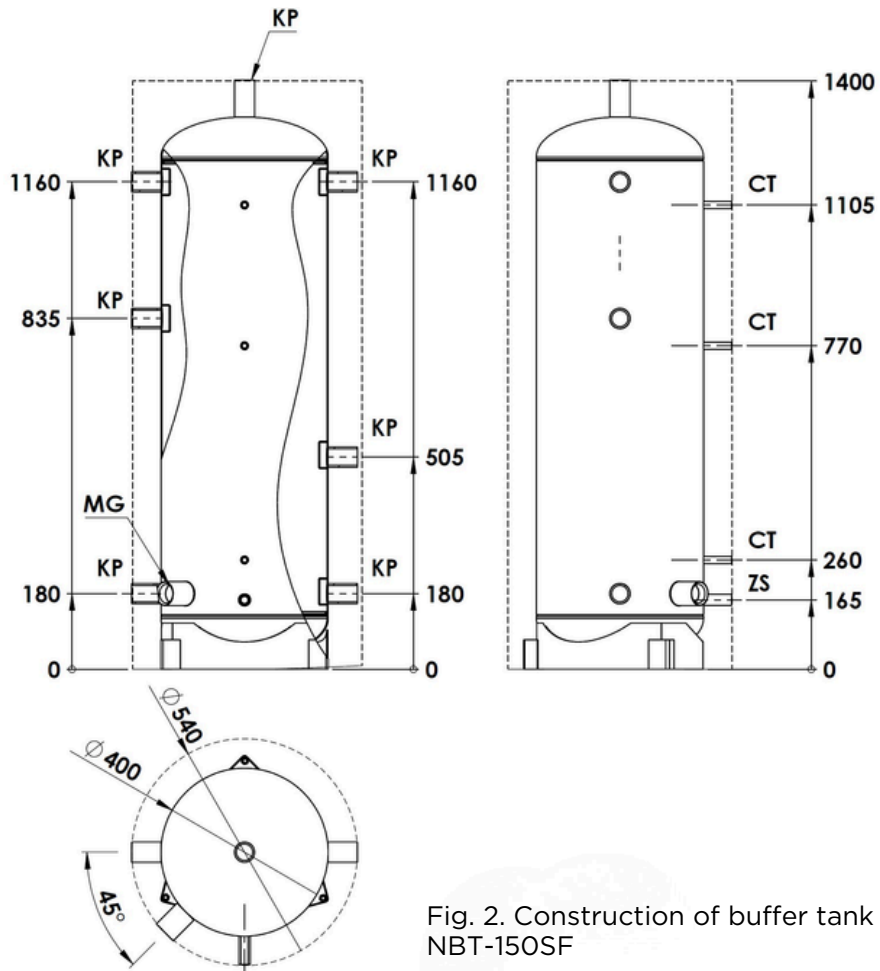

Fig. 2. Construction of buffer tank NBT-150SF

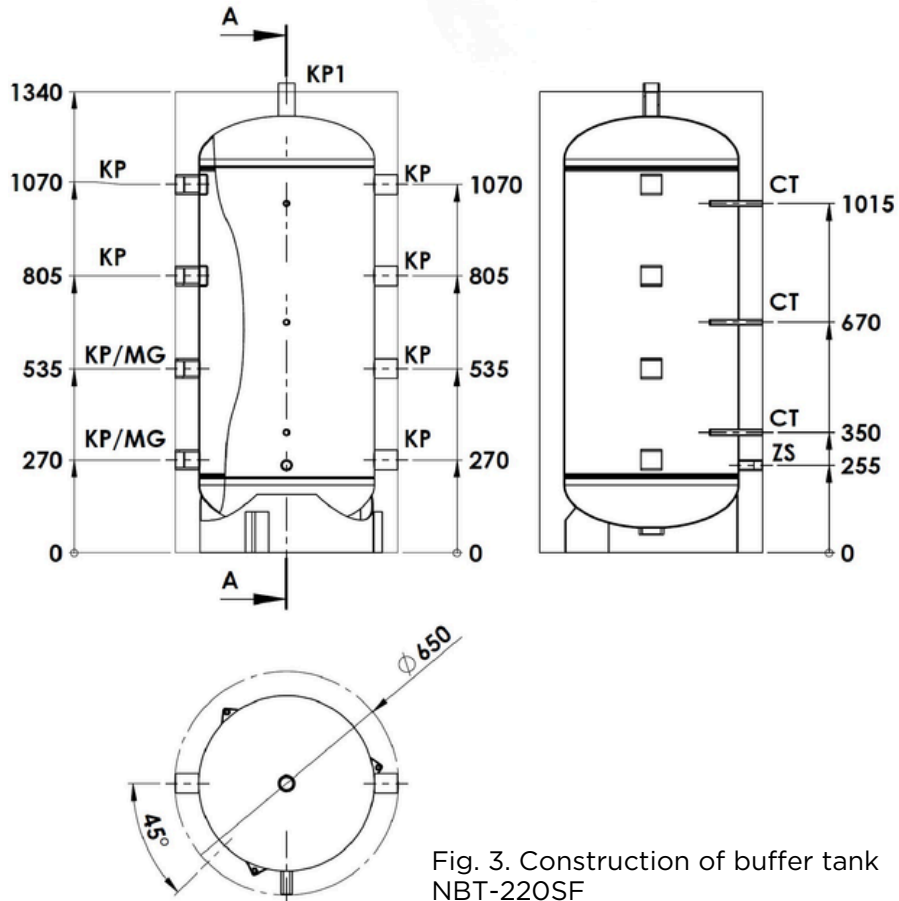

Fig. 3. Construction of buffer tank NBT-220SF

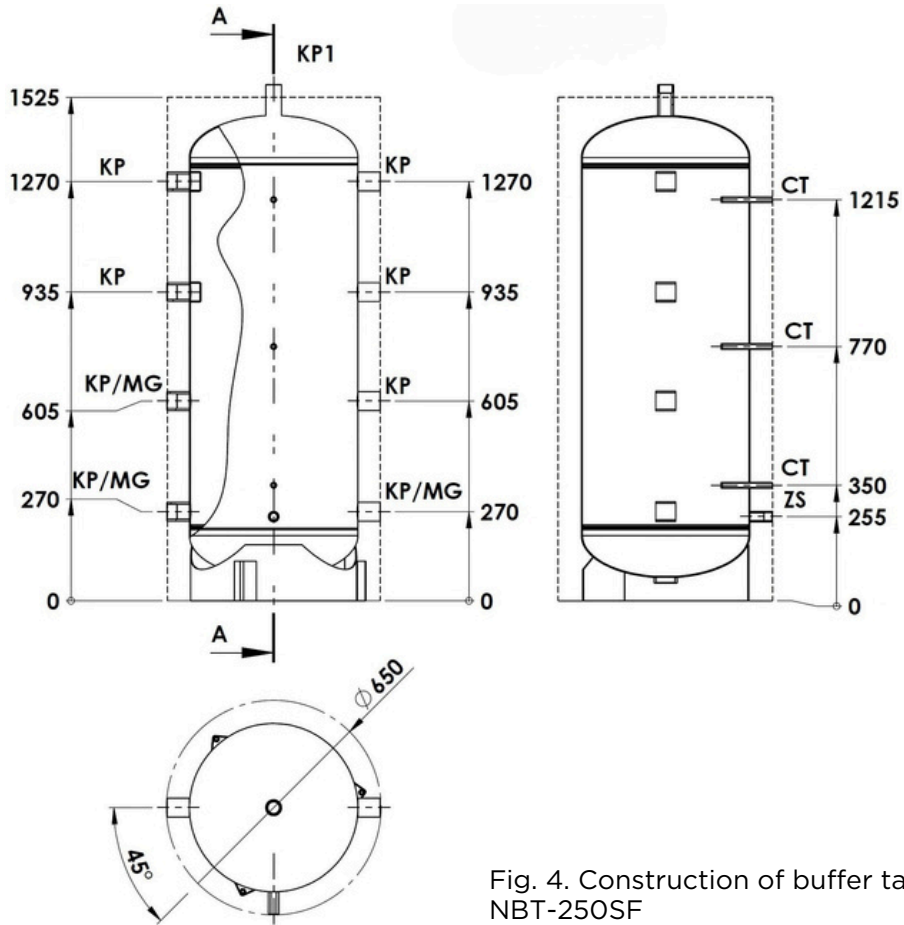

Fig. 4. Construction of buffer tanks NBT-250SF

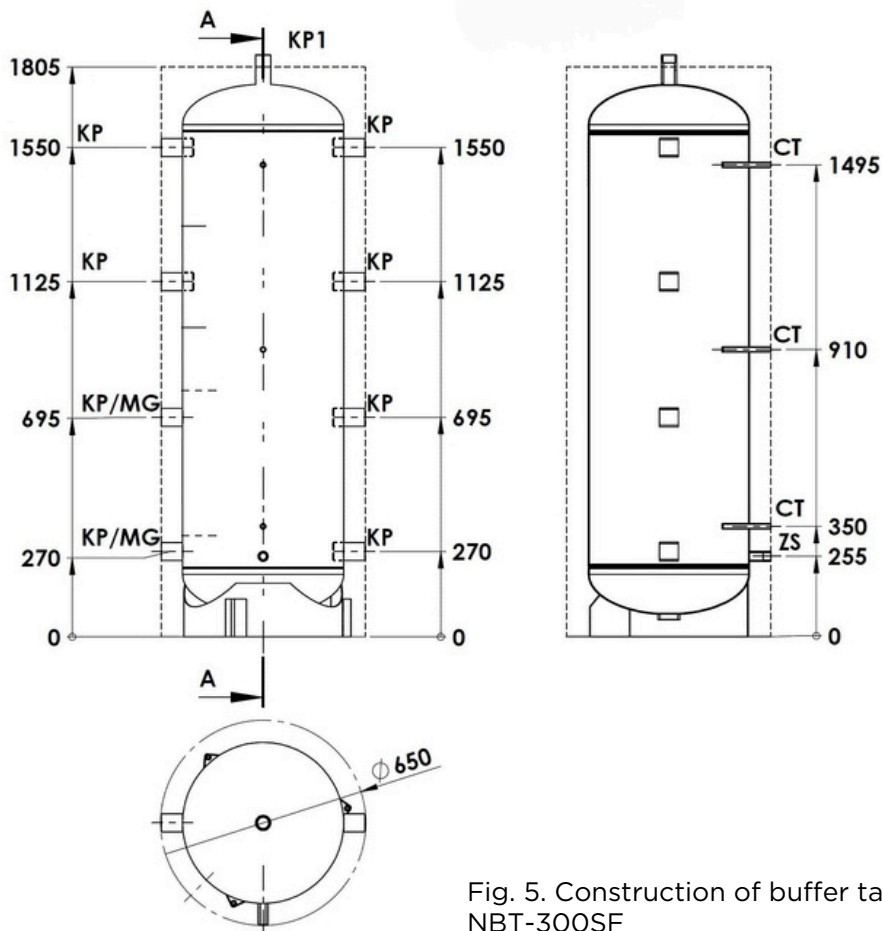

Fig. 5. Construction of buffer tanks NBT-300SF

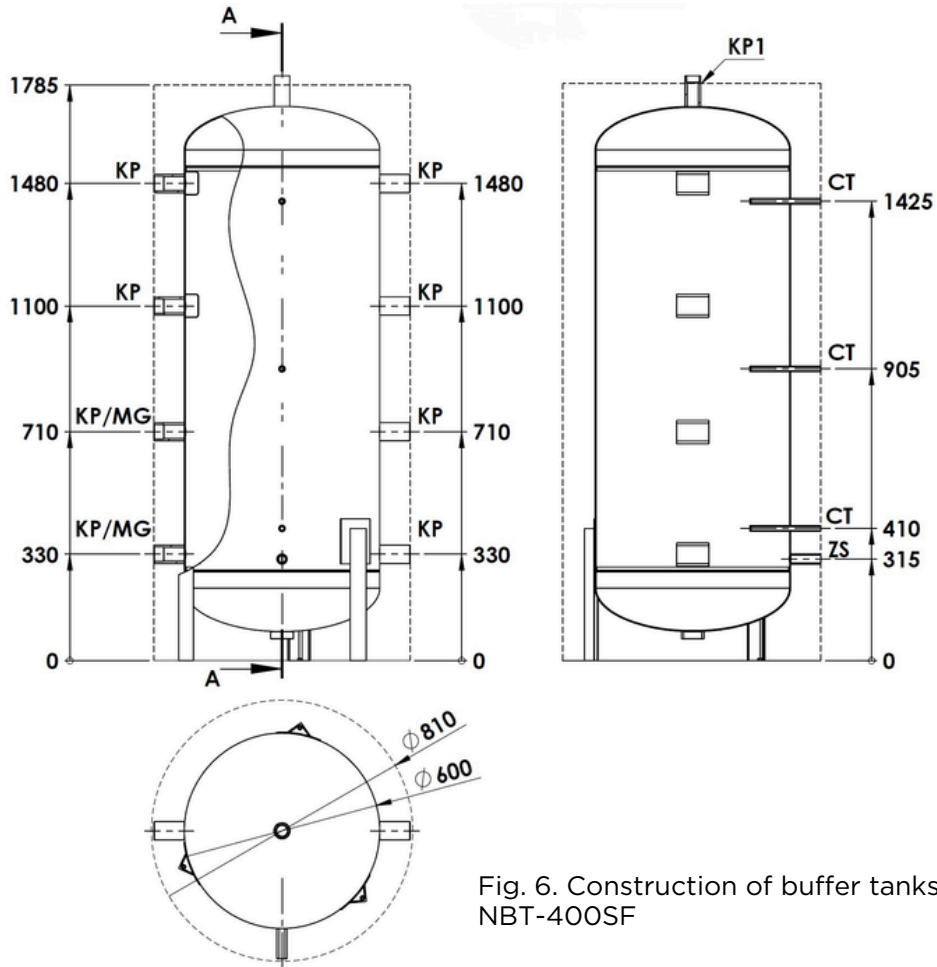

Fig. 6. Construction of buffer tanks NBT-400SF

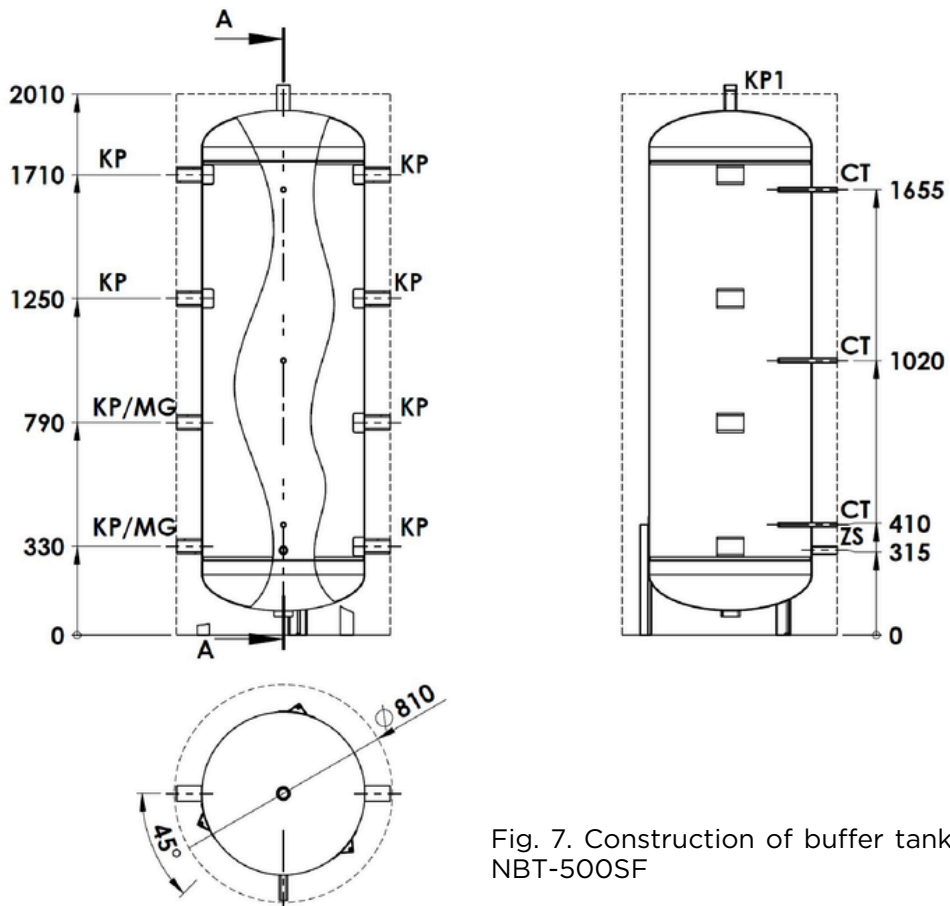

Fig. 7. Construction of buffer tanks NBT-500SF

Table 1. Dimensions and parameters of the NBT-SF tanks

Parameter	Unit	NBT-100SF	NBT-150SF	NBT-220SF	NBT-250SF	NBT-300SF	NBT-400SF	NBT-500SF
Storage capacity	l	105	147	222	262	318	433	498
Connection stub KP1		-	-	G 1 ¼"	G 1 ¼"	G 1 ¼"	G 1 ¼"	G 1 ¼"
Heater connector MG		G 1 ½"	G 1 ½"	G 1 ½"	G 1 ½"	G 1 ½"	G 1 ½"	G 1 ½"
Connection stub KP		G 1 ¼"	G 1 ¼"	G 1 ½"	G 1 ½"	G 1 ½"	G 1 ½"	G 1 ½"
Temperature sensor closed CT		¾"	¾"	¾"	¾"	¾"	¾"	¾"
Drain ZS		G 1 ½"	G 1 ½"	G 1 ¾"	G 1 ¾"	G 1 ¾"	G 1 ¾"	G 1 ¾"
Standing losses* (polystyrene foam)	W	32	43	52	61	72	60	67
Standing losses* (rubber mat)	W	28	38	47	55	65	54	61
Type of tank		steel - raw inside, outside covered with anti-corrosion paint						
Thermal insulation	mm	70	70	70	70	70	100	100
Outer cover		skay type material						
Tank operating parameters (in polystyrene foam insulation)		Maximum operating pressure and temperature: pr = 0.3 MPa; tr min = 15°C tr max = 80°C						
Tank operating parameters (insulated with rubber mat)		Maximum operating pressure and temperature: pr = 0.3 MPa; tr min = 5°C tr max = 70°C						
Weight	kg	40	50	57	67	87	95	120

*in accordance with the applicable EU Commission Regulation No. 812/2013 and 814/2013

2. Security and conditions for safe use.

Tanks, especially those operating in closed systems, must only be operated with a functional safety valve with a maximum opening pressure of 0.3 MPa, preferably installed on the cold water inlet. This valve protects the device against excessive pressure buildup in the heating circuit.

Even during normal operation, water may occasionally escape from the safety valve, indicating that the valve is functioning properly. In such cases, the discharge opening should not be obstructed in any way.



1. A safety valve must be installed on the cold water inlet to the tank. It should be installed so that the arrowhead on the valve body aligns with the direction of water flow.
2. No shut-off valves should be installed between the safety valve and the tank.
3. Operating the tank without a safety valve or with a faulty safety valve is prohibited as it may cause a malfunction and poses a threat to human life and health.
4. For a safety valve that has, among other functions, the function of reducing the water pressure in the tank by flowing it into the supply system, the water supply system at a distance of at least 5 m from the valve should be resistant to a temperature of +90°C.

3. Operation and maintenance.

3. Operation and maintenance.

1. Periodically, at least once a month and before each start-up after shutdown from operation, the correct operation of the safety valve should be checked.

Repairs to water installations should only be carried out by professionals with appropriate qualifications.

3.1. Installing a heater with an electric heater.

During the tank warranty period, only electric heaters with insulated heating elements may be used. This is one of the warranty conditions for the heater.

Installation should be carried out in accordance with the installation and operating instructions for the electric heater.

- 1 - tank housing
- 2 - electric heater
- 3 - MG 1 ½" connector

Fig. 8. Installing the electric heater

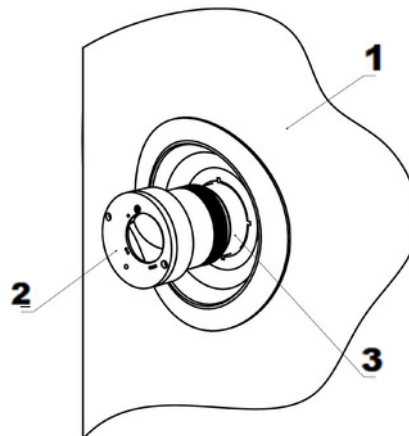

Among the heaters manufactured by Nordis , single-phase 230 V heaters with a power of 1.5, 2.0, or 3.0 kW and three-phase 400 V heaters with a power of 3.0, 4.5, or 6.0 kW are installed in the heaters. The design possibilities for each electric heater are presented in Table 2.

Table 2. Selection of electric heaters for NBT-SF tanks.

DHW type/ Heater type	1500 W (230V)	2000 W (230V)	3000 W (230V)	3000 W (400V)	4500 W (400V)	6000 W (400V)
NBT-100SF	✓	✓	✓	✓	X	X
NBT-150SF	✓	✓	✓	✓	X	X
NBT-220SF	✓	✓	✓	✓	✓	X
NBT-250SF	✓	✓	✓	✓	✓	X
NBT-300SF	✓	✓	✓	✓	✓	X
NBT-400SF	✓	✓	✓	✓	✓	✓
NBT-500SF	✓	✓	✓	✓	✓	✓

A single-phase water heater with an electric element should be connected to the mains via a 230V/16A grounded socket. Connection of the water heater to the mains is indicated by a green light, and activation of the water heater is indicated by a red light. The electrical diagrams for the water heaters are shown in Fig. 9.

- 1-heating element
- 2-temperature regulator + temperature limiter
- 3-resistor
- 4-rectifier diode
- 5-red light-emitting diode
- 6-metal head

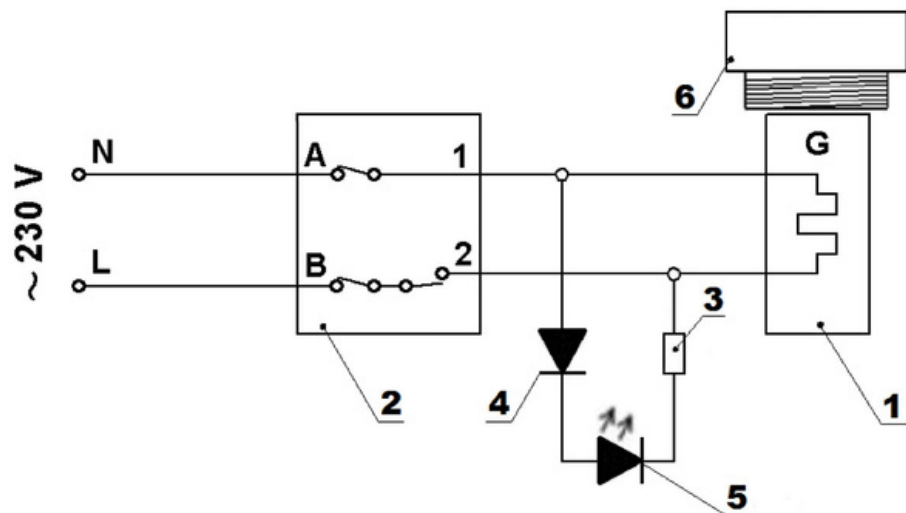

Fig. 9. Electrical diagram of a heater with a 1-phase electric heater.



Connection of a water heater with a 3-phase electric heater to the system in accordance with the electrical diagram (Fig. 10) should be performed by a qualified professional.

- 1-heating element
- 2-temperature controller + temperature limiter
- 3-resistor
- 4-metal head
- LS-LED diode - signaling

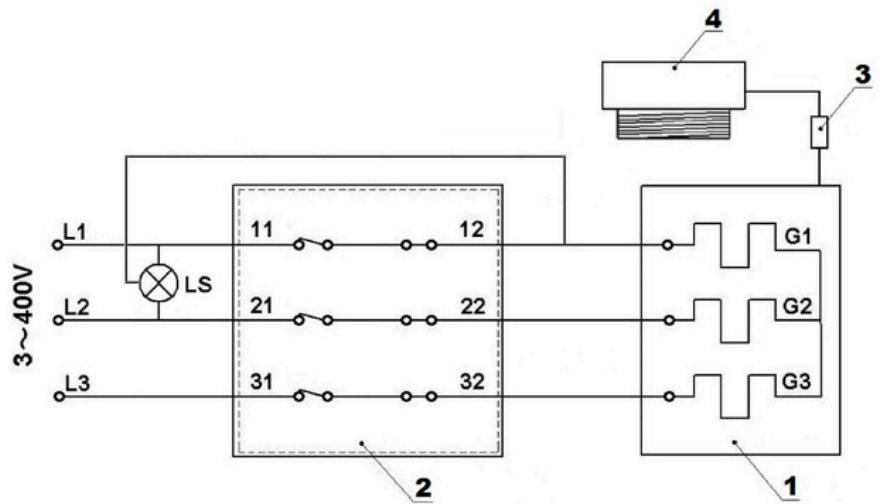

Fig.10 Electrical diagram of a heater with a 3-phase electric heater



Do not plug the power cord into an electrical outlet without first ensuring the tank is filled with water.

4. Warranty terms

1. The warranty for the tank (i.e. the steel body of the heat exchanger) is 60 months.
2. The warranty for the remaining parts of the tank is 24 months.
3. The warranty period starts from the date of sale of the product to the user, as specified in the card warranty and confirmed by a purchase document (invoice) issued by the seller.
4. The guarantor guarantees the proper operation of the device provided that it is installed and used in accordance with this operating manual, i.e., above all, provided that the permissible pressure is not exceeded and that treated boiler water is used.
5. During the warranty period, the user is entitled to free repairs of device damage caused by the manufacturer. Such damage will be repaired within 14 days of the report date.
6. The user loses the right to warranty repairs in the event of:
 - improper use of the device,
 - repairs and modifications to the device performed by unauthorized persons,
 - improper installation and operation of the device not in accordance with this manual,
 - operation of the tank without a safety valve or with a faulty safety valve,
 - removal of the thermal insulation permanently attached to the pressure tank.
7. The guarantor may refuse to perform repairs if:
 - access to the device is not provided,
 - replacing the tank requires the removal of other devices, partition walls, etc.,
 - the tank is permanently connected to the water supply system using non-detachable connections.
8. Each service request is preceded by a preliminary inspection to determine whether the defect described by the customer exists and whether it was caused by the user's improper use of the device.
9. In the event of a service call for an event not covered by the warranty, i.e. after the warranty period, the costs of the service visit and the ordered repair are borne by the customer.
10. If any irregularities occur in the operation of the device, please notify the manufacturer's service department by phone at +370 37 373248, or by email at service@nordis-ac.com, or at the point of purchase. **DO NOT DISASSEMBLE THE DEVICE.**
11. The method of repairing the device is determined by the manufacturer.
12. The basis for carrying out repairs under the warranty is a properly completed and stamped warranty card containing no amendments.
13. In matters not covered by the above terms, the provisions of the Civil Code shall apply.



More information about
NØRDIS heating and
cooling solutions

www.nordis-ac.com